

RCV155 - Wire Rope Cutter Part No - 980218

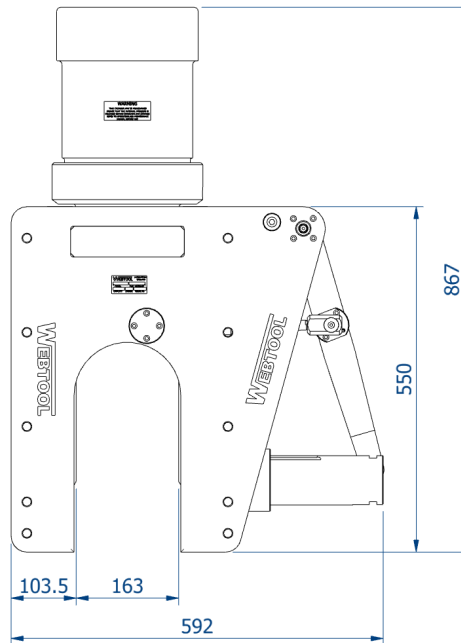

- Heavy duty wire rope cutter designed for use in severe working conditions
- Hydraulically operated anvil for easy ROV deployment
- Robust plated steel and stainless steel construction
- All steel components are electroless nickel plated to resist corrosion
- Long blade life ensures that tool maintenance is kept to a minimum
- Optional intensifier panel is available
- Cutting capacity – Maximum $\varnothing 155\text{mm}$ wire rope of 1880N/mm² grade
- Can be used at any water depth
- Suitable for cutting wire rope, cables and umbilicals
- 690 bar maximum input pressure for main cylinder
- 210 bar max input pressure for anvil
- Approx weight – 240kg
- Standard tool is shown above. Bespoke and custom designs to suit special applications are available on request

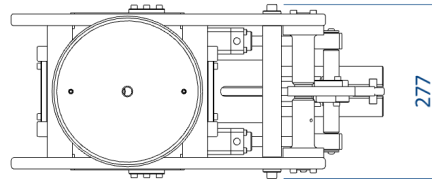

PHONE: 1.416.234.8671 **FAX:** 1.416.237.9279

EMAIL: info@webtool-subsea.com

61 Advance Rd., Unit 7, Toronto,
Ontario, Canada M8Z 2S6

WEBTOOL-SUBSEA.COM

allspeeds
www.allspeeds.co.uk

Webtool is a Trademark of Allspeeds Ltd
Designed and Manufactured in the UK