

Gemini NBI

Narrow Beam Imaging



Operating at 620kHz the Gemini NBI is able to produce images with 10mm range resolution while the 0.5° horizontal angular resolution results in an extremely sharp sonar image. Where monitoring your position relative to a known target is the objective, and not general obstacle avoidance, then the Gemini NBI can help guide you safely to the desired target.

The multibeam transducer design used for the Gemini NBI results in a 130° sector scan width and advanced technology allows update rates as high as 30 scans per second. With wide angle imaging and a high refresh rate the user is able to quickly and effectively manoeuvre to a target in poor visibility conditions.

Depth rated to 4000m and manufactured from titanium the Gemini NBI has been designed to work in the harshest of environments such as those typically found in subsea mining and excavation.

Gemini NBI can be supplied with either Ethernet or VDSL communication allowing the system to interface to deep water systems with multiplexers as well as shallow water systems where there may only be a copper shielded twisted pair (STP) available. The Gemini NBI software can be run on the Trittech Surface Control Unit (SCU) or installed on the customers own laptop PC.

The Gemini NBI offers a narrow vertical beam and 130° swath

The Gemini NBI produces an acoustic image, cutting through the water with a narrow acoustic beam and at the high refresh rate offered from the Gemini range of multibeam sonars. Based on the proven design of the Gemini 720i, the Gemini NBI uses a 1° vertical beam instead of the 20° vertical beam found on the 720i. This reduced beam width allows the user to more precisely identify the position of the acoustic targets than is possible with a wide beam imaging sonar which is commonly used for obstacle avoidance operations.

Benefits

- High speed updates
- 4000m titanium housing
- Solid-state design reliability
- Easy to use software package

Features

- Ethernet or VDSL communication
- 130° swath
- 1° vertical beam
- 0.5° effective angular resolution

Applications

- Pipe and cable lay tracking
- Trenching operation monitoring
- Mining visualisation
- ROV/AUV navigation

Specification

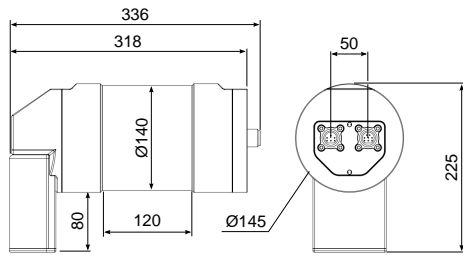

Not to scale, dimensions in mm.

Forward Facing NBI

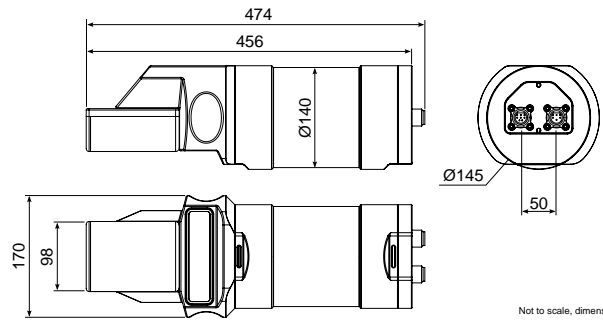

Not to scale, dimensions in mm.

Downward Facing NBI

Acoustic Properties	
Operating Frequency	620kHz
Angular Resolution	1.0° acoustic, 0.5° effective
Scanning Sector	130°
Number of Beams	256
Vertical Beamwidth	1°
Range	0.5 to 120m
Scan Rate	5 - 30Hz (range dependent)
Range Resolution	10mm (range dependent)

Electrical and Communications	
Power Consumption	37W max (range dependent, head unit only)
Supply Voltage	20 - 75V DC
Data Communications	Ethernet (up to 80m) or VDSL (up to 1000m)



VDSL Cable Length

Maximum length for VDSL and power is 300m, if power is provided locally (e.g., by the ROV) then maximum cable length for VDSL communication is 1000m.

Physical Properties		
Property	Forward Facing	Downward Facing
Weight	14.6kg air, 9.5kg water	19kg air, 13kg water
Depth Rating	4000m	
Material	Titanium (6 AL-4V)	
Finish	Bead blasted	
Operating Temperature	-10 to 35°C	
Storage Temperature	-20 to 50°C	

Specifications subject to change according to a policy of continual development.

Document: 0695-SOM-00005, Issue: 01

Marketed by:

Tritech International Ltd
 Peregrine Road, Westhill Business Park
 Westhill, Aberdeenshire, AB32 6JL
 United Kingdom
 sales@tritech.co.uk
 +44(0)1224 744 111

