

Datasheet

Lodestar - GyroCompatt 6



Description

Lodestar GyroCompatt 6 integrates Sonardyne's Wideband® 2 acoustic positioning and Lodestar AHRS technology in one small, highly versatile and robust instrument. This provides high update rate wireless attitude, heading, heave, surge, sway, temperature, pressure, SV and acoustic positioning of any subsea object.

Compatible with USBL and LBL positioning systems, the Lodestar GyroCompatt 6 provides real time motion data for structure deployment via the integrated high speed acoustic modem.

The internal high capacity rechargeable battery pack enables quick charge times and up to 28 hours of continuous operation with the ability to turn the gyro on and off to save battery life giving over two months of transponder life.

The instrument is small and light enough to be ROV installed and a mechanical stab enables precision alignment to any structure.

Applications

Structure position and orientation can be accurately determined during

lowering, set-down and as-built surveys. Using the Lodestar GyroCompatt 6 for metrology delivers the measurements required for pipe-end coupling.

The stab, gyro and transducer are pre-aligned and this speeds up spot measurements as only single observations are required.

Autonomous logging negates the need for a vessel and ROV to be on standby taking measurement during long term settlement observations.

Modular construction allows for upgrade and service access to the transponder module.

Key Features

- Sonardyne Wideband® 2 acoustic positioning transponder and Lodestar AHRS unit in a single unit
- Rechargeable 28 hr internal battery pack; option for external power
- Acoustic, serial and manual ROV On/Off switch for Lodestar AHRS
- Sonardyne Wideband® and Kongsberg HPR 400 compatible
- Autonomous data logging mode (All sensor data and ranges)
- Faster command and configuration
- Simultaneous ranging and sensor data telemetry in one transmission
- Integrated sound speed & high accuracy pressure sensor with a port for additional auxiliary sensors
- Real time diagnostics on range measurements for quality control
- Optional calibrated stab pre-aligned to all instrument axes
- Compact size for ease of handling and ROV deployment/recovery
- INS data logged internally for post processing via 10/100 Ethernet
- High speed acoustic modem
- Data telegram output and 12V available for ROV displays

Multi-sensor and acoustic transducer endcap

3,000 metre depth rated housing

Lodestar AHRS sensor



Specifications

Lodestar - GyroCompatt 6

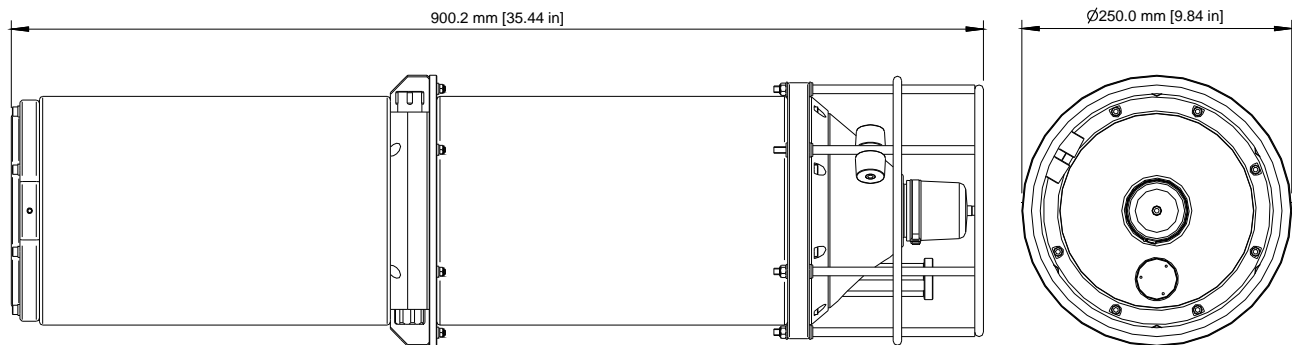

Feature		Type 8084-000-3164	
Depth rating		3,000 Metres	
Operating Temperature		-10°C to +50°C	
Operational Shock Rating		22 g, 11 ms half sine	
External Battery Pack / ROV Supply		24 V (20 – 50 V)	
Battery Life	Acoustic Navigation Standby	3 Months	
	Lodestar Permanently Powered On	28 Hours	
Acoustic	Compatt 6	Operating Frequency	MF (19-36kHz) Sonardyne Wideband® 2
		Transmit Source Level	185-192dB re 1µPa @ 1m (5 Levels)
		Ranging Precision	Better than 15 mm
		Telemetry Protocol	Sonardyne SMS and Modem
		Ranges Tracked	14 Simultaneous Replies
Lodestar AHRS	Heading	Range	0-360°
		Accuracy	0.1° Secant Latitude
		Settle Time	<5 Minutes
		Follow Up Speed	500° / Second
		Resolution	0.01°
	Roll and Pitch	Range	±180° (No physical limit)
		Accuracy	0.01°
		Resolution	0.01°
	Heave	Range	±99 m
		Accuracy (Real Time)	5 cm or 5% (Whichever is the greater)
Bandwidth		User selectable	
	Resolution	0.01 m	
Digital Output	Output Telegram (e.g. For ROV LED display)	Yes	
ROV Switch	Contact Closure	Yes	
Data Back-up	Data Logger	8GB (expandable to 32GB) internal memory to allow post processing	
Remote Transducer	For ROV applications, a remote transducer is available		
Sensors	Sound Speed Sensor	±0.03 m/s	
	Pressure – Strain Gauge or Digiquartz	0.01% FS	
Physical	Size (Dia x Length)	250 mm x 900.2 mm	
	Weight in Air / Weight in Water	45 kg / 17 kg	

*Depends on knowledge of sound speed

Specifications subject to change without notice – 05/2013