

Innomar *deep-36* Parametric Sub-Bottom Profiler

1 Overview

The “INNOMAR *deep-36*” is a parametric sub-bottom profiler for a wide range of applications requiring high spatial resolution in water depths between 5 and 6,000 meters. This model incorporates a parametric narrow-beam sub-bottom profiler (SBP; frequency band 1–10 kHz) with single-beam echo sounder functionality (frequency c. 36 kHz). During rough sea conditions the results will be improved by heave compensation and electronic beam stabilization. There are two model versions, one with heave and roll compensation (“Basic”) and one with additional pitch compensation (“RP”). Full-waveform data are recorded digitally on an internal hard disk.

2 Applications

- Surveys for general geological/geophysical or environmental investigations (seabed structure, sediment properties, sediment thickness, climate research);
- Surveys at offshore building sites (e.g., wind farms, oil rigs, bridges, tunnels);
- Route surveys for pipeline / cable laying;
- Pipeline / cable as-laid and maintenance surveys;
- Detection of buried objects like pipelines, cables, UXO and archaeological objects;
- Surveys for dredging projects, maintenance of ports and water ways;
- Search for mineral resources and deposits (gravel, sand, hydrocarbons);
- Hydrographic surveying.

3 Technical Specifications

Primary High Frequencies (PHF)	approx. 36 kHz (band 30 – 42 kHz)
Primary Source Level / Acoustic Power	> 246 dB/μPa re 1m / c. 9 kW
Secondary Low Frequencies (SLF)	2, 3, 4, 5, 6, 7 kHz (centre frequency, user selectable)
SLF Total Frequency Band	1 – 10 kHz
SLF Source Level	c. 208 dB/μPa re 1m
SLF Pulse Type	Ricker, CW, FM (chirp 2 – 7 kHz)
SLF Pulse Width	0.15 – 1.5 ms (CW, user selectable); 5 ms (FM chirp)
Beam Width (-3dB)	about ±1.5° for all frequencies / footprint <5.5% of water depth
Heave / Roll / Pitch compensation	heave / roll (30°) / pitch (20°; optional “RP”); depending on external sensor data
Water Depth Range	5 – 6,000 m below transducer
Sediment Penetration	soft clay: 150 m, coarse sand: 20 m; depending on noise, pulse settings and geological conditions
Range Resolution / Layer Resolution	<2 cm / up to 12 cm (depending on pulse settings)
Pulse Rate	up to 40 pings/s (multi ping, burst ping available)
Data Acquisition and Recording	digital 24 bit / 48 kHz; full waveform
External Sensor Interfaces	HRP (motion), GNSS position, depth (all RS232 / UDP), trigger
Bottom Detection	internal (HF and LF data) or external depth
Depth Accuracy	(6 cm @ 36 kHz / 12 cm @ 4 kHz) + 0.06% of water depth; complies to IHO-S44, but not certified
Survey Vessel Speed	up to 15 knots (depending on survey goal, weather conditions)
Control PC	Built-in (MS Windows® 10 OS, proc. i5 or better, 8 GB RAM, 1 TB SSD, Geforce GT710 1 GB graphics card or better, 1 Gbit Ethernet, 3×USB3.0, 2×USB2.0, 4×RS232, 1×HDMI1.4a)
Remote Control / Survey Integration	KVM / basic functions via COM or Ethernet (UDP)
Dimension / Weight	See below
Power Supply	100 – 240 V AC / 50 – 60 Hz (fuse 16 A / slow)
Power Consumption	<900 W (max. power-on inrush current 25 A / <100 ms)
Environmental Conditions	Storage: -10...+60°C / <90% non-condensing rel. humidity Operation: 0...+40°C / <70% non-condensing rel. Humidity

4 Wiring Schematic / Connections

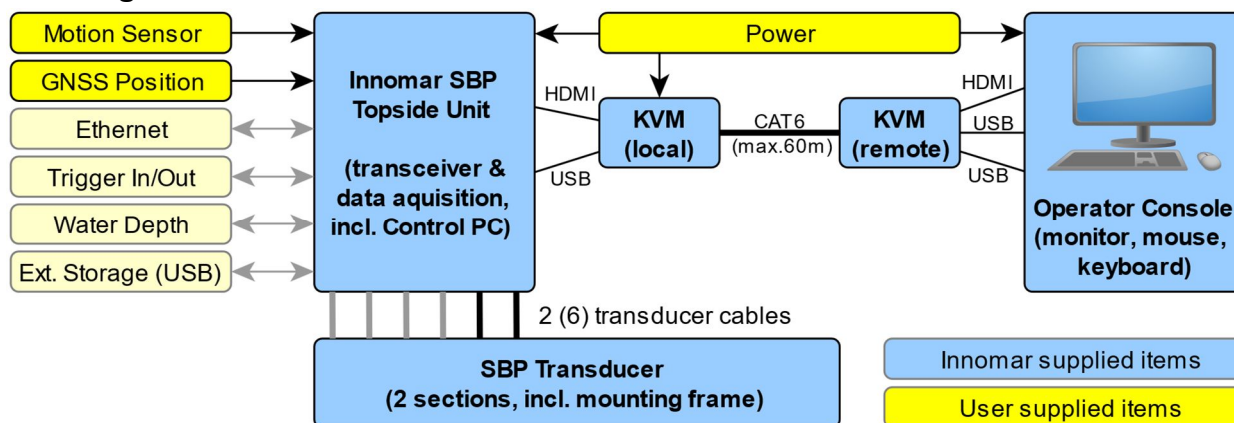

5 Topside Unit



(picture shows "Basic" version)

There is one (1) topside unit, which contains all transceiver electronics, data acquisition and the Windows based control PC. Dimensions and weight depend on the model version:

	"Basic" version (Heave + Roll)	"RP" version (Heave + Roll + Pitch)
Dimensions (L×W×H)	52 cm × 50 cm × 50 cm	52 cm × 50 cm × 63 cm
Housing	19 inch / 10 U	19 inch / 13 U
Weight	c. 56 kg	c. 66 kg

The topside unit is preferably installed using shock absorbers (provided by Innomar) in an air-conditioned room. There has to be enough space for connections and maintenance as well as air venting around the unit.

6 Transducer

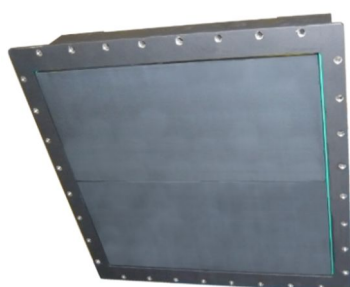

	excl. mounting frame	incl. mounting frame
Dimensions (L×W×H)	75 cm × 80 cm × 16 cm	88 cm × 92 cm × 18 cm
Weight (excl. cables)	c. 165 kg	c. 245 kg
Weight (incl. cables)	c. 215 kg ("Basic" ver.) c. 300 kg ("RP" version)	c. 300 kg ("Basic" vers.) c. 380 kg ("RP" version)

The transducer is used for transmitting and receiving, and is usually mounted to the vessel in a sea-chest or blister. There is no towed equipment required.

The transducer consists of two sections and there is one cable moulded non-removable to each transducer section. For the "RP" model version there are three cables per section. The standard cable length is 30 meters.

Both transducer sections are mounted into a frame with shock absorbers to avoid structure-borne noise picked up.

7 INNOMAR Software

The delivery contains a software package:

- **“SESWIN” online data acquisition software** provides a straightforward interface to configure and control the system parameters during survey. Online echo plots are used for quality assurance. There is also a interface for using third-party survey software like HYPACK or QINSY.
- **“SES-Netview” remote display software:** is used for online display of SBP data and system settings on slave monitors for QC/QA and supervision.
- **“SES-Convert” data converter software:** can be used to export Innomar data formats into industry-standard formats like SEG-Y to use third-party software for post-processing.
- **“ISE” post-processing software:** used for data replay and to process the digitally stored Innomar data. A project-based workflow allows intuitive handling of 2D seismic sections together with a GIS map window. The processing includes signal filtering, noise reduction, tide and vertical corrections, cleaning of external sensor data, picking of seabed and sub-seabed reflectors and targets and the overlay of external probe and core data to assist interpretation. Raw, processed and interpreted data can be exported to various industry-standard formats, such as SEG-Y, XTF and ASCII.

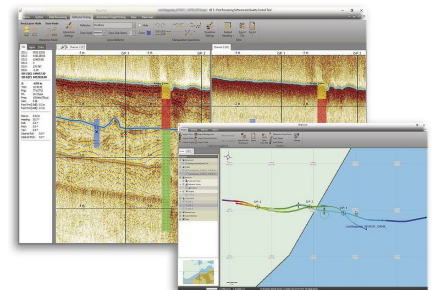
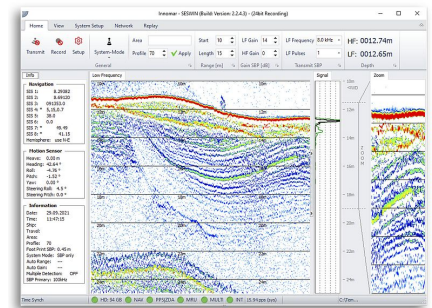

8 Advantages / User Benefits

- High spatial resolution due to narrow sound beam, high ping rate and wide bandwidth.
- Very narrow acoustic beam (half-power beam width c. $\pm 1.5^\circ$ for all frequencies).
- No sidelobes for the LF beam \rightarrow less ambiguities and spurious signals.
- Wide frequency bandwidth \rightarrow very short pulses with high range resolution possible.
- User selectable ping characteristics (Ricker, CW): centre frequency, pulse width.
- Frequency modulated pings (chirp) for improved performance in deeper waters.
- High ping rate even in deeper water due to multi-ping and burst-ping modes.
- Data heave and roll (and pitch) stabilized during TX and RX \rightarrow increased weather window.
- HF (36 kHz) echo-sounder function for exact water depth determination.
- Hull mounted transducer \rightarrow no towed items to be deployed/recovered.
- High availability due to increased weather window and low maintenance requirements.
- Real-time processing and echo-print visualisation.
- Direct or remote-controlled operation (KVM, Ethernet).
- Automatic gain and range control for watch-free operation.
- Soft-start for protecting marine mammals.
- Slave display of data and system parameters via Ethernet for QC/supervision.
- Wide range of auxiliary sensors from different manufacturers (GNSS, RPH) supported.
- Advanced synchronisation (trigger) interface to reduce acoustic interferences with MBES.
- Digital data acquisition (24-bit / 48 kHz full waveform data).
- Automatic data backup on a central data server (NAS).
- Automatic survey log in text format (line start/stop, GNSS position, depth, etc.).
- Automatic alarms on system or sensor errors and on low record disk space.
- Data export to industry standard data formats like SEG-Y, XTF, ASCII.

9 Data Examples

All data examples shown below were acquired using the “Basic” system variant.

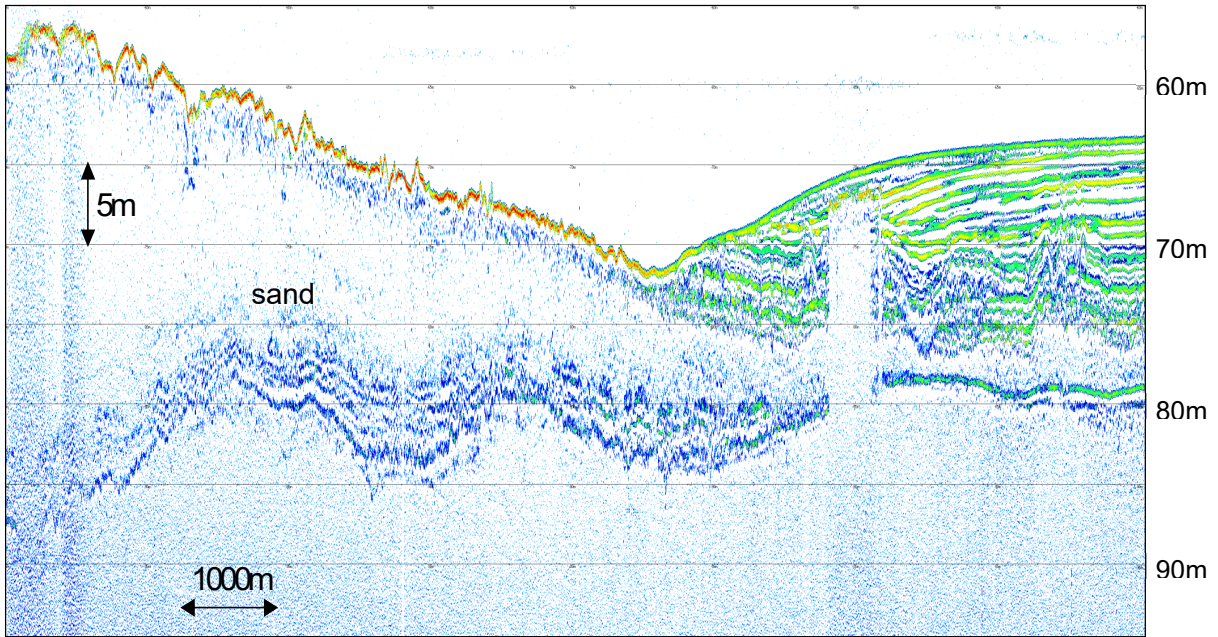

INNOMAR deep-36 data example from a shallow water area
(water depth about 50-200m; penetration approx. 30m into sand; frequency 5kHz / 800 μ s)

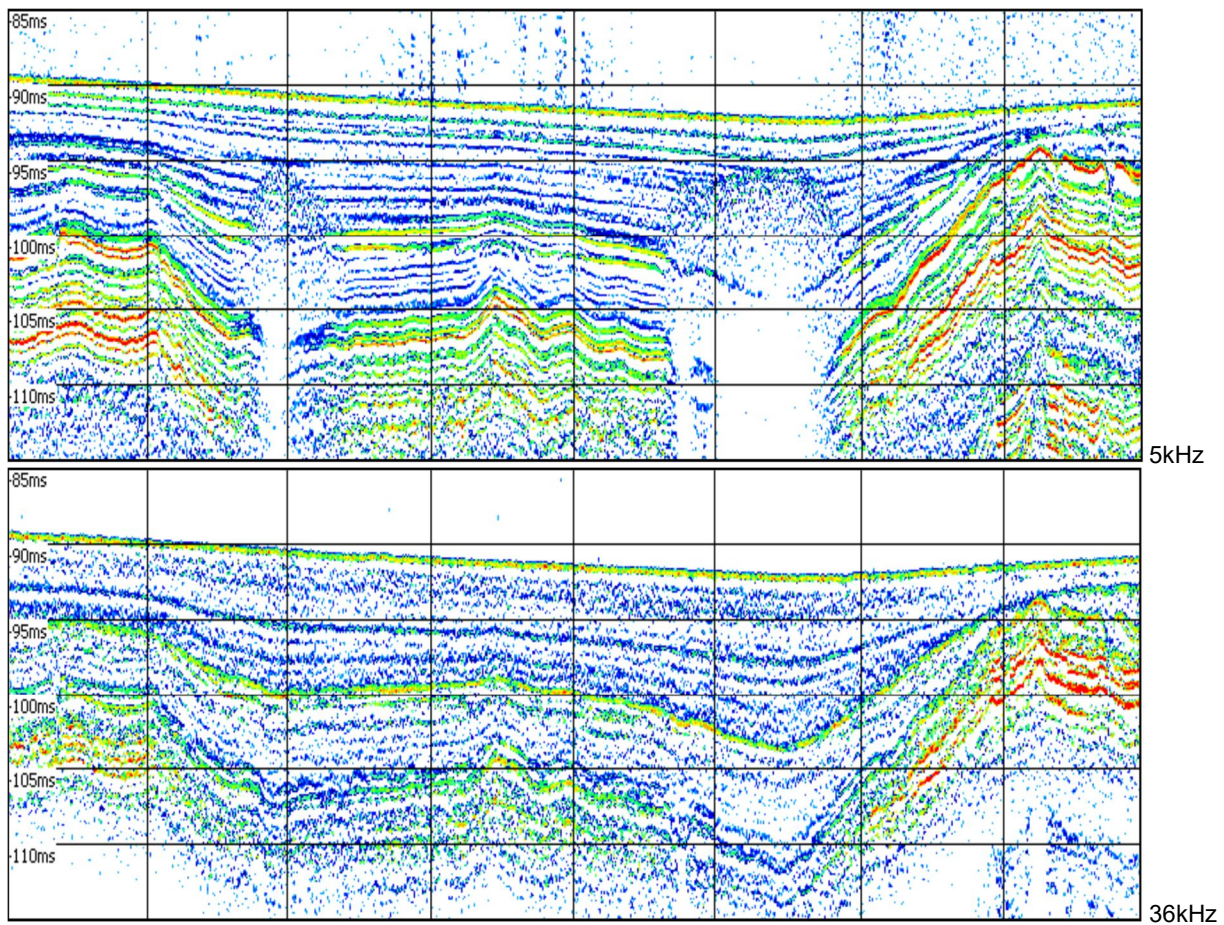

INNOMAR deep-36 data example at two different frequencies (top 5 kHz; bottom 36 kHz)
in an area with sediments containing shallow gas (water depth approx. 70m)

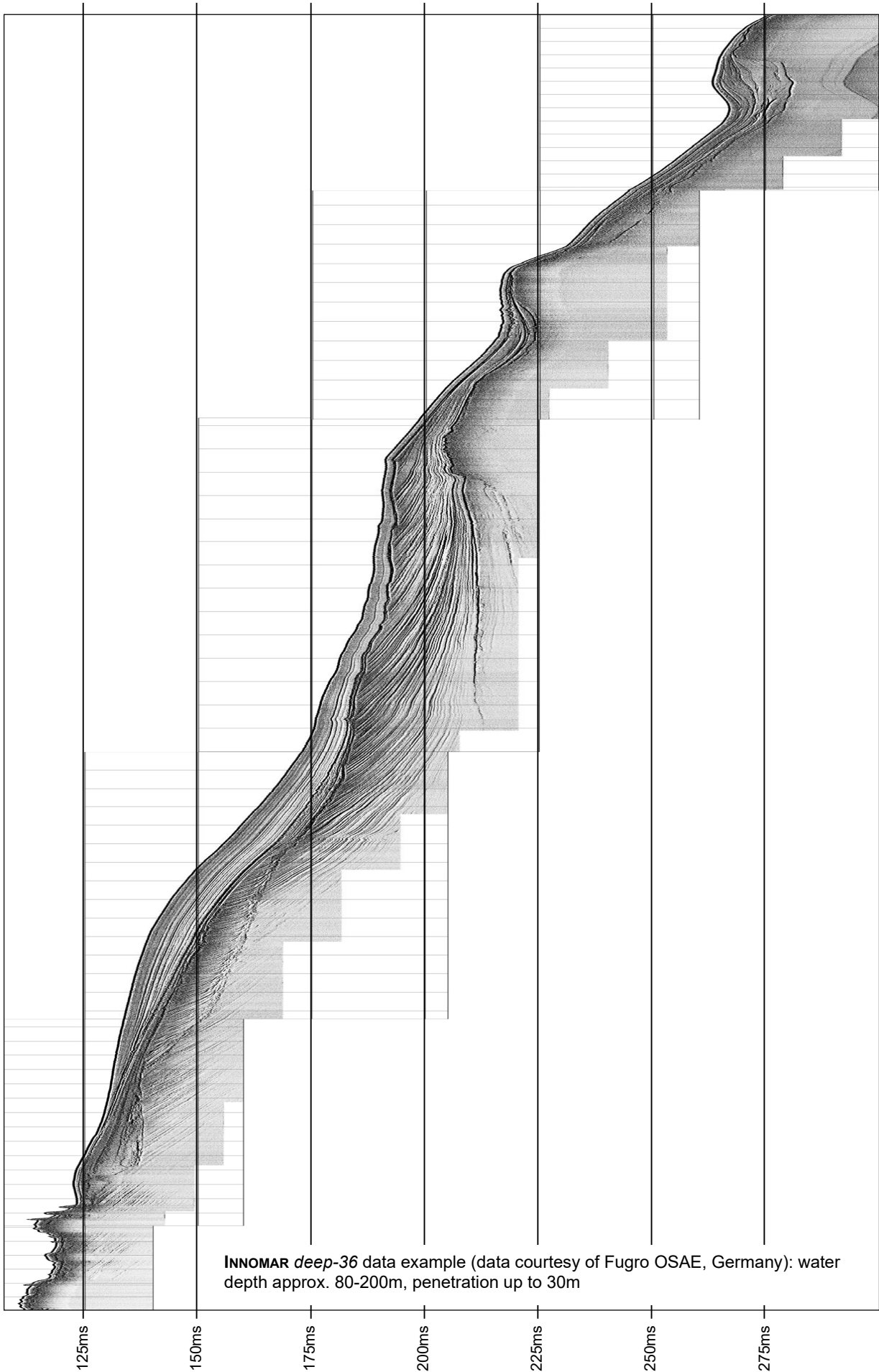

INNOMAR *deep-36* data example (data courtesy of Fugro OSAE, Germany): water depth approx. 80-200m, penetration up to 30m

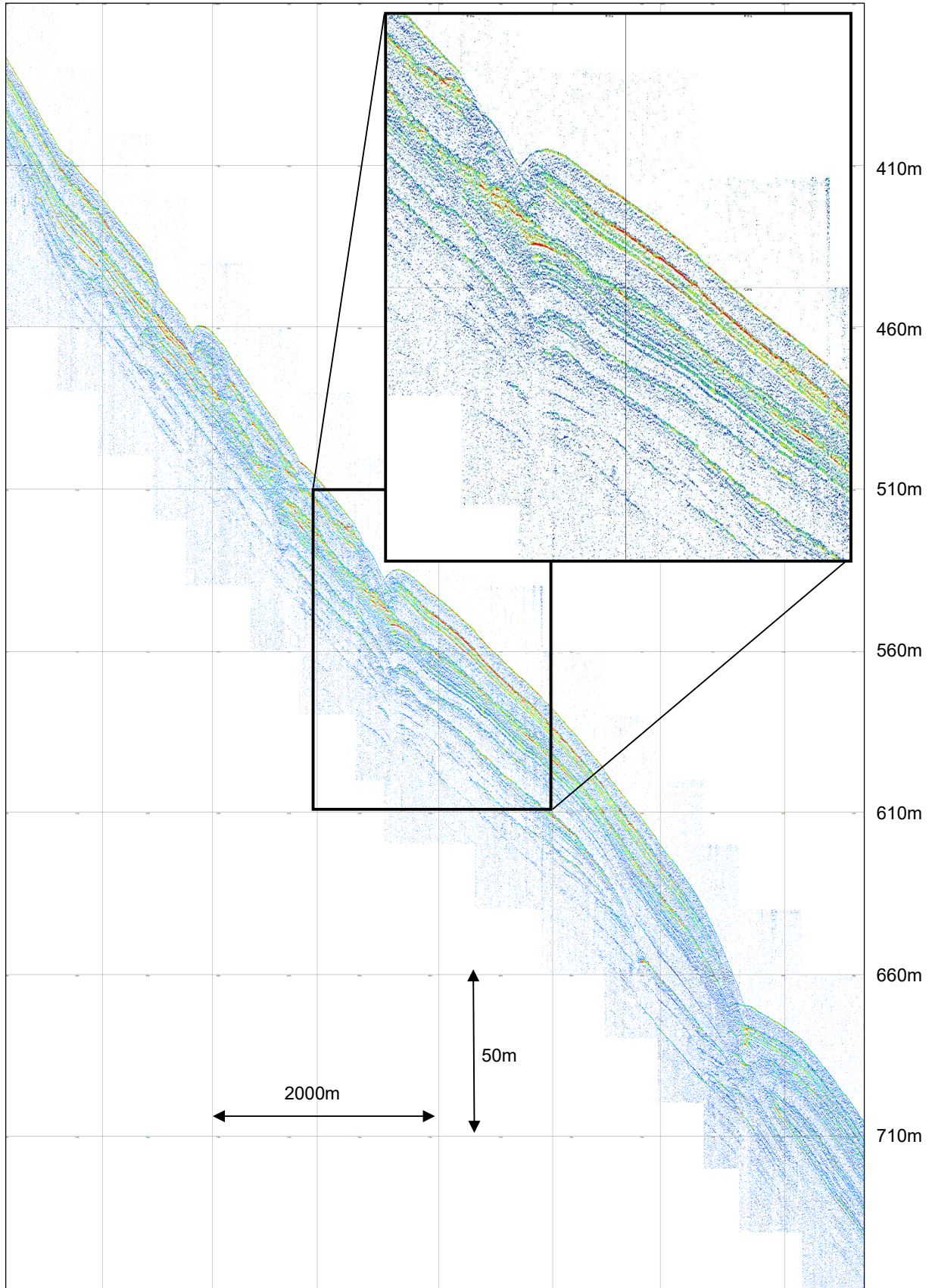

INNOMAR deep-36 ('POD' pitch option) data example from a slope of 2.5 degrees, equivalent to about 4.5% (water depth about 360-710m; penetration approx. 60m; frequency 4kHz / 500 μ s; survey speed about 13 knots)

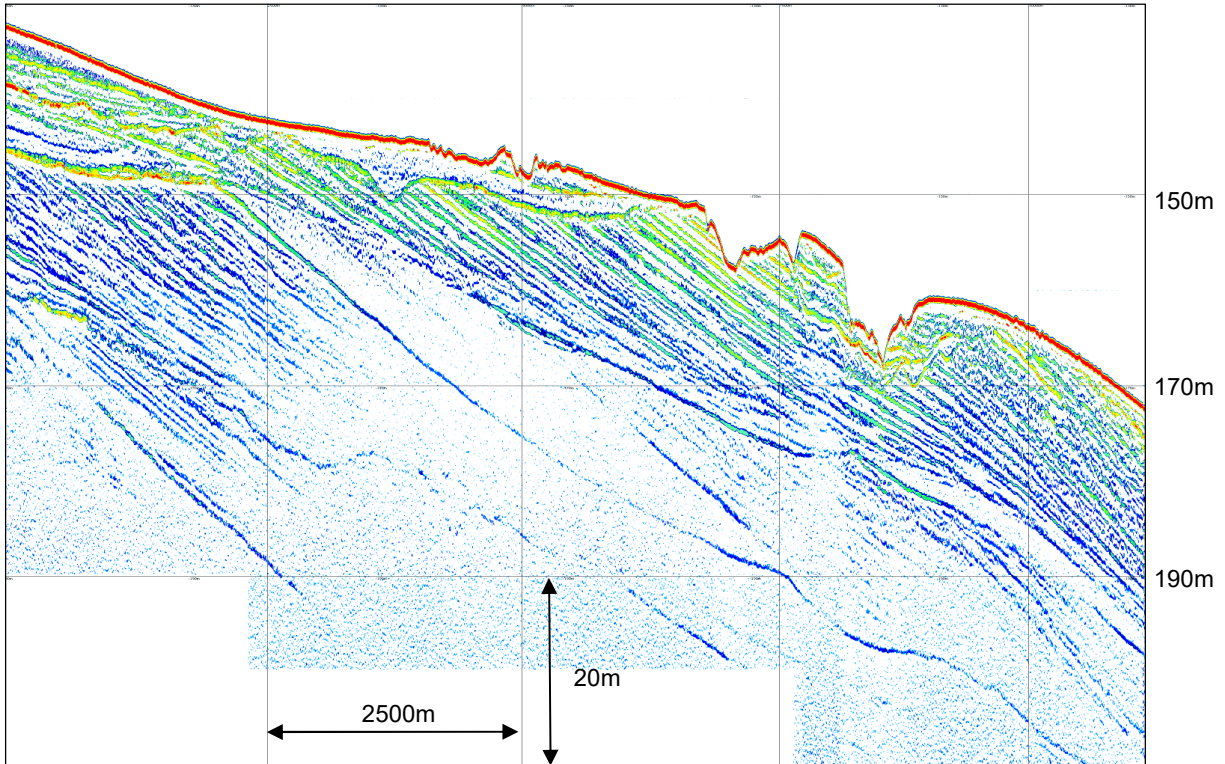

INNOMAR deep-36 data echo print example from shallow water, ship speed about 13 knots (water depth about 150m; penetration approx. 50m; frequency 4kHz / 750µs)

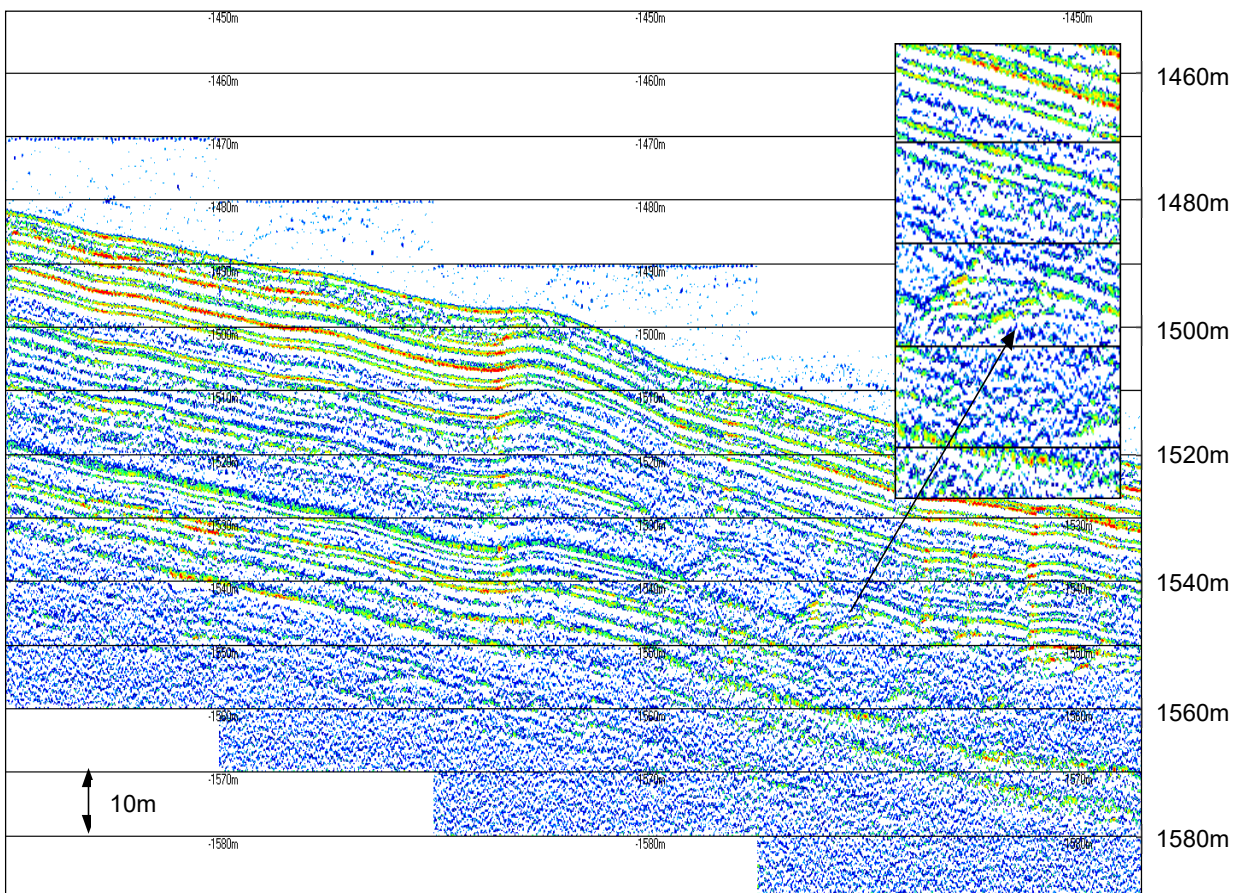

INNOMAR deep-36 data example operating in medium water-depth area off Greenland (water depth about 1,500m; frequency 4kHz; sediment penetration approx. 60m)

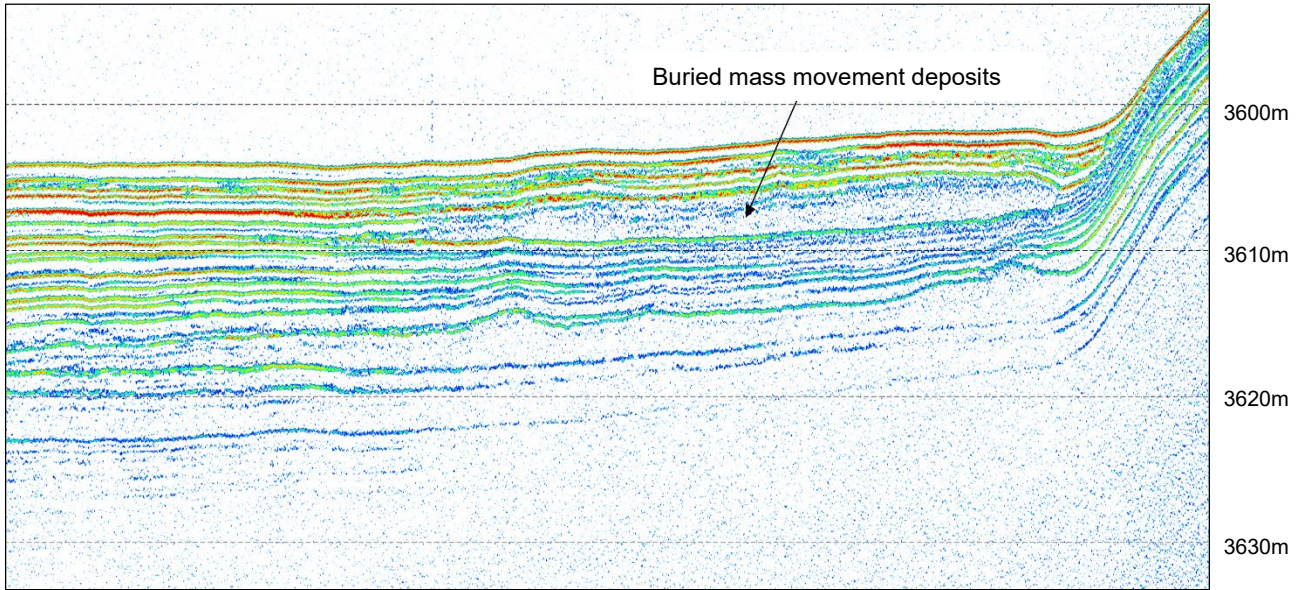

SES-2000 *deep-36* echo print example from Comoro Islands (data courtesy of Fugro OSAE, Germany)
(water depth about 3,600m; penetration approx. 20m; frequency 6kHz / 333 μ s; ping rate 7s⁻¹;
profile length 27km, survey speed 10knots)

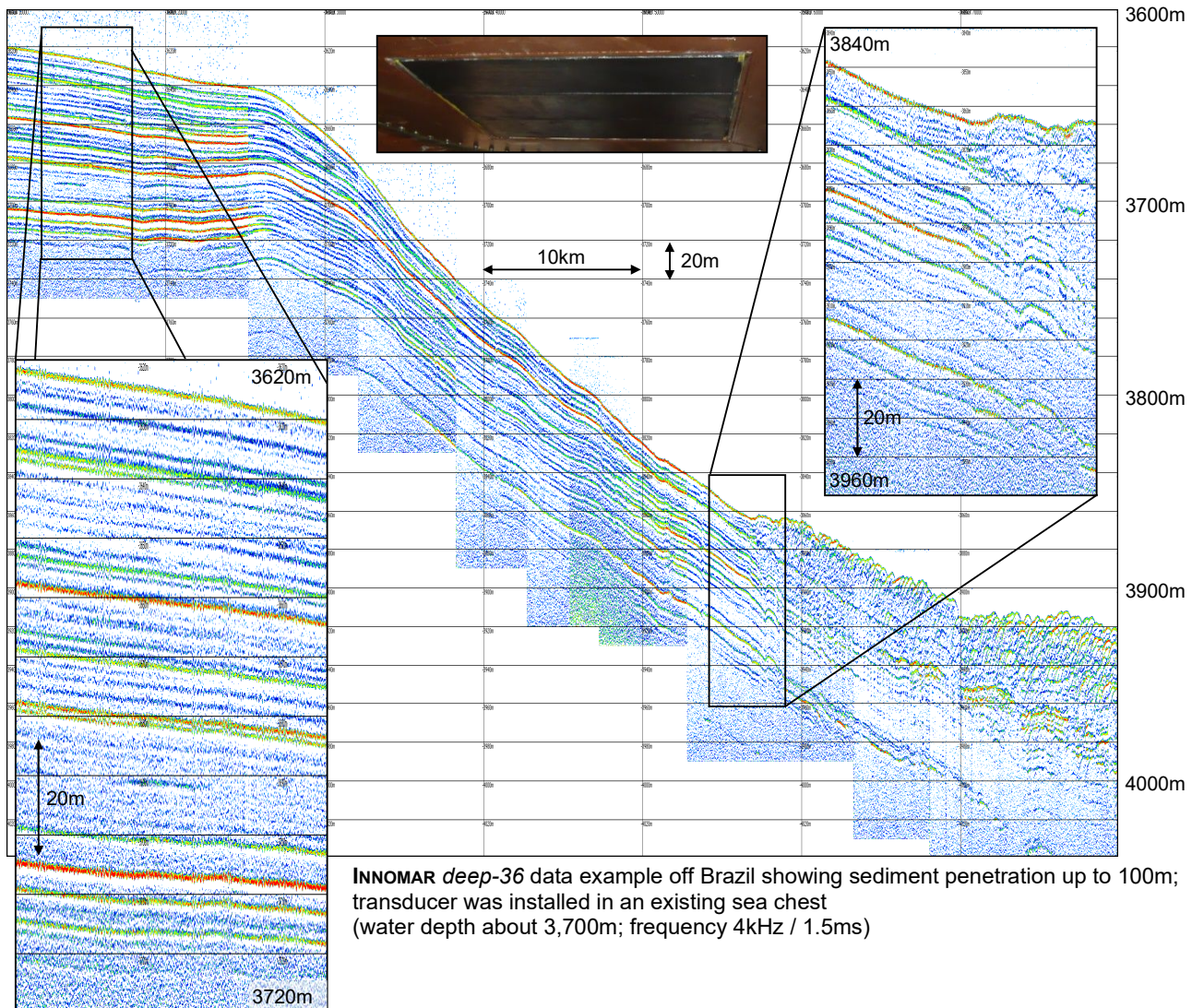

INNOVAR *deep-36* data example off Brazil showing sediment penetration up to 100m;
transducer was installed in an existing sea chest
(water depth about 3,700m; frequency 4kHz / 1.5ms)

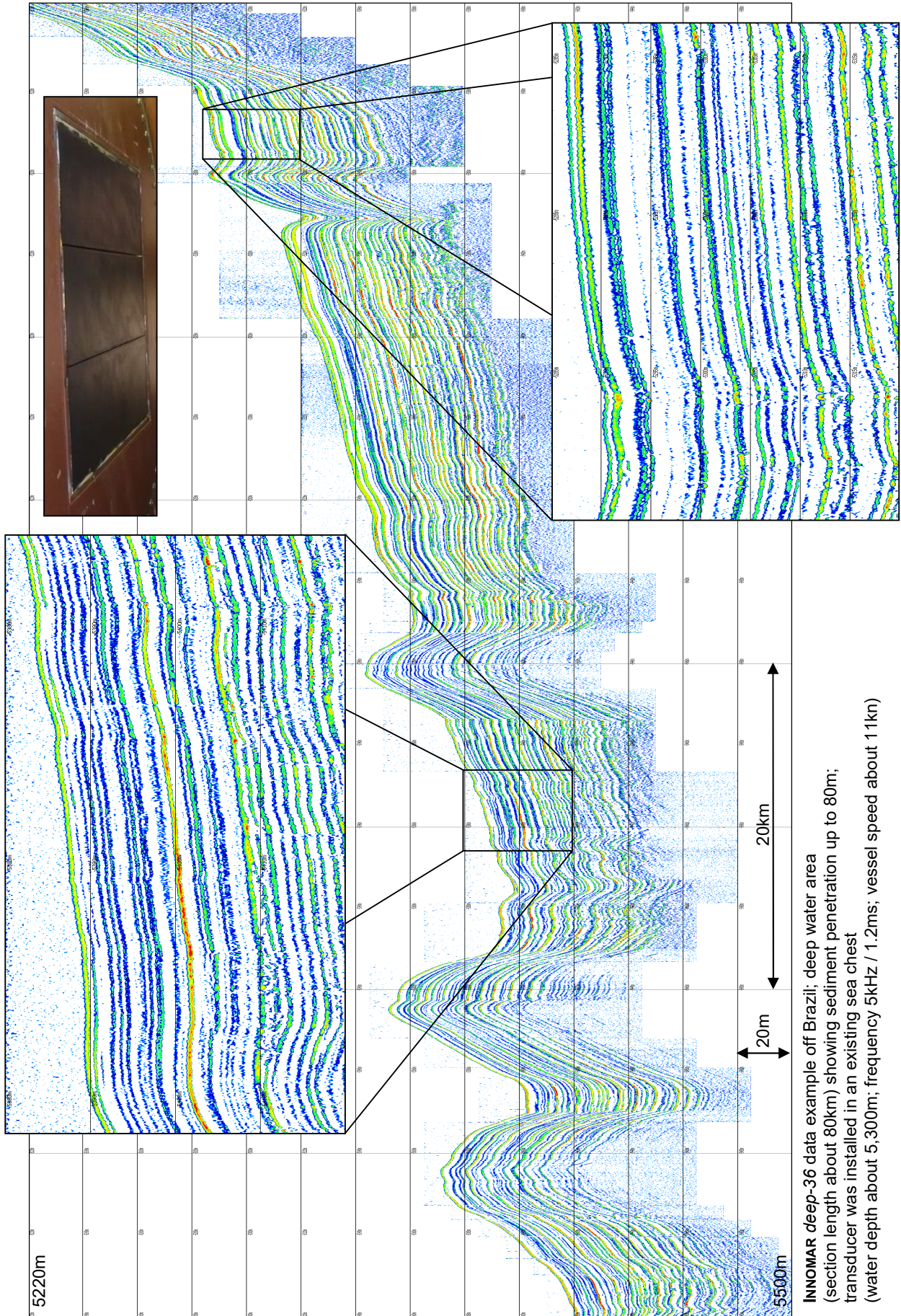

INNOMAR deep-36 data example off Brazil; deep water area (section length about 80km) showing sediment penetration up to 80m; transducer was installed in an existing sea chest (water depth about 5,300m; frequency 5kHz / 1.2ms; vessel speed about 1 kn)